

Please write clearly in block capitals.

Centre number

--	--	--	--	--

Candidate number

--	--	--	--

Surname

Forename(s)

Candidate signature

A-level PHYSICS

Paper 2

Friday 24 May 2019

Morning

Time allowed: 2 hours

Materials

For this paper you must have:

- a pencil and a ruler
- a scientific calculator
- a Data and Formulae Booklet.

Instructions

- Use black ink or black ball-point pen.
- Fill in the boxes at the top of this page.
- Answer **all** questions.
- You must answer the questions in the spaces provided. Do not write outside the box around each page or on blank pages.
- If you need extra space for your answer(s), use the lined pages at the end of this book. Write the question number against your answer(s).
- Do all rough work in this book. Cross through any work you do not want to be marked.
- Show all your working.

Information

- The marks for questions are shown in brackets.
- The maximum mark for this paper is 85.
- You are expected to use a scientific calculator where appropriate.
- A Data and Formulae Booklet is provided as a loose insert.

For Examiner's Use	
Question	Mark
1	
2	
3	
4	
5	
6	
7–31	
TOTAL	



Section A*Do not write
outside the
box*Answer **all** questions in this section.**0 1**

Figure 1 shows a perfectly insulated cylinder containing 0.050 kg of liquid nitrogen at a temperature of 70 K.

A heater transfers energy at a constant rate of 12 W to the nitrogen.

A piston maintains the pressure at 1.0×10^5 Pa during the heating process.

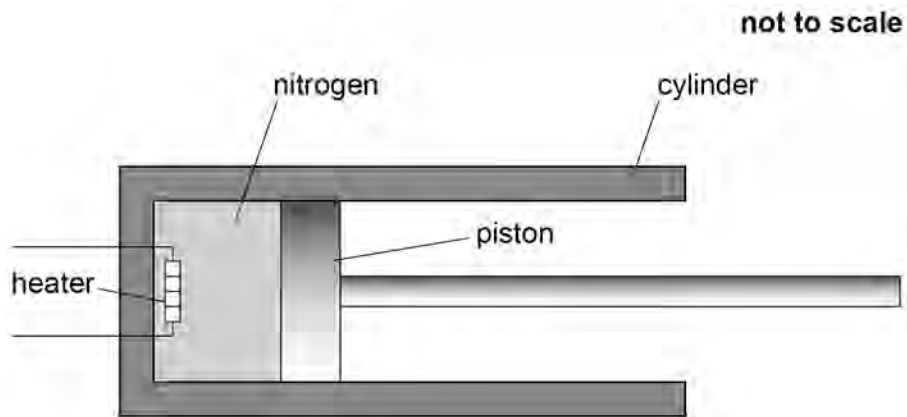
Figure 1

0	1	.	1
---	---	---	---

The nitrogen is heated from 70 K and is completely turned into a gas after 890 s.

Calculate the specific heat capacity of liquid nitrogen.
Give an appropriate unit for your answer.

specific latent heat of vaporisation of nitrogen = $2.0 \times 10^5 \text{ J kg}^{-1}$

boiling point of nitrogen = 77 K

[5 marks]

specific heat capacity = _____ unit = _____

Question 1 continues on the next page

Turn over ►



0 1 . 2

The work done by the nitrogen in the cylinder when expanding due to a change of state is **X**.

The energy required to change the state of the nitrogen from a liquid to a gas is **Y**.

Deduce which is greater, **X** or **Y**.

density of liquid nitrogen at its boiling temperature = 810 kg m^{-3}

density of nitrogen gas at its boiling temperature = 3.8 kg m^{-3}

[4 marks]

9



0 2 . 1

State what is meant by the internal energy of a gas.

[2 marks]

0 2 . 2

Absolute zero of temperature can be interpreted in terms of the ideal gas laws or the kinetic energy of particles in an ideal gas.

Describe these two interpretations of absolute zero of temperature.

[2 marks]

Question 2 continues on the next page**Turn over ►**

0 2 . 3

A mixture of argon atoms and helium atoms is in a cylinder enclosed with a piston. The mixture is at a temperature of 310 K.

Calculate the root mean square speed (c_{rms}) of the argon atoms in the mixture.

$$\text{molar mass of argon} = 4.0 \times 10^{-2} \text{ kg mol}^{-1}$$

[3 marks]

$$c_{\text{rms}} = \text{_____} \text{ m s}^{-1}$$

0 2 . 4

Compare the mean kinetic energy of the argon atoms and the helium atoms in the mixture.

[1 mark]

0 2 . 5

Explain, in terms of the kinetic theory model, why a pressure is exerted by the gas on the piston.

[3 marks]



0 3 . 1 Define gravitational potential at a point.

[1 mark]

0 3 . 2 **Figure 2** shows the positions of equipotential surfaces at different distances from the centre of the Moon.

Figure 2

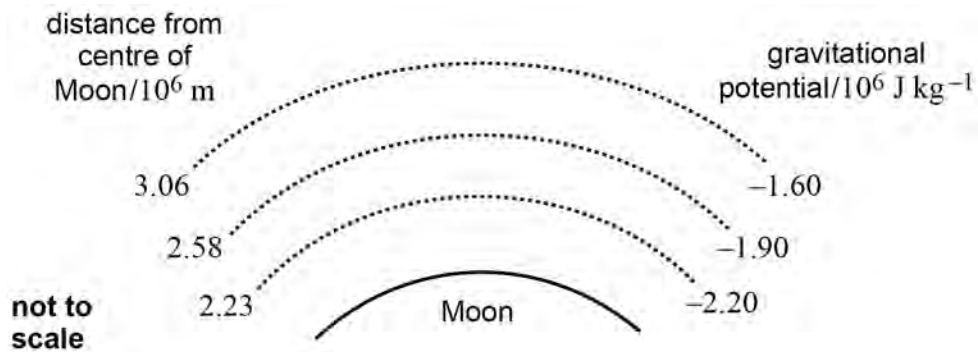

Explain how the equipotential surfaces in **Figure 2** show that the gravitational field is **not** uniform.

[1 mark]



0 3 . 3

Calculate, using **Figure 2**, the escape velocity at the surface of the Moon.

$$\text{radius of Moon} = 1.74 \times 10^6 \text{ m}$$

[4 marks]escape velocity = _____ m s^{-1}

6**Turn over for the next question****Turn over ►**

0 4

Figure 3 shows an arrangement used to investigate the repulsive forces between two identical charged conducting spheres. The spheres are suspended by non-conducting thread.

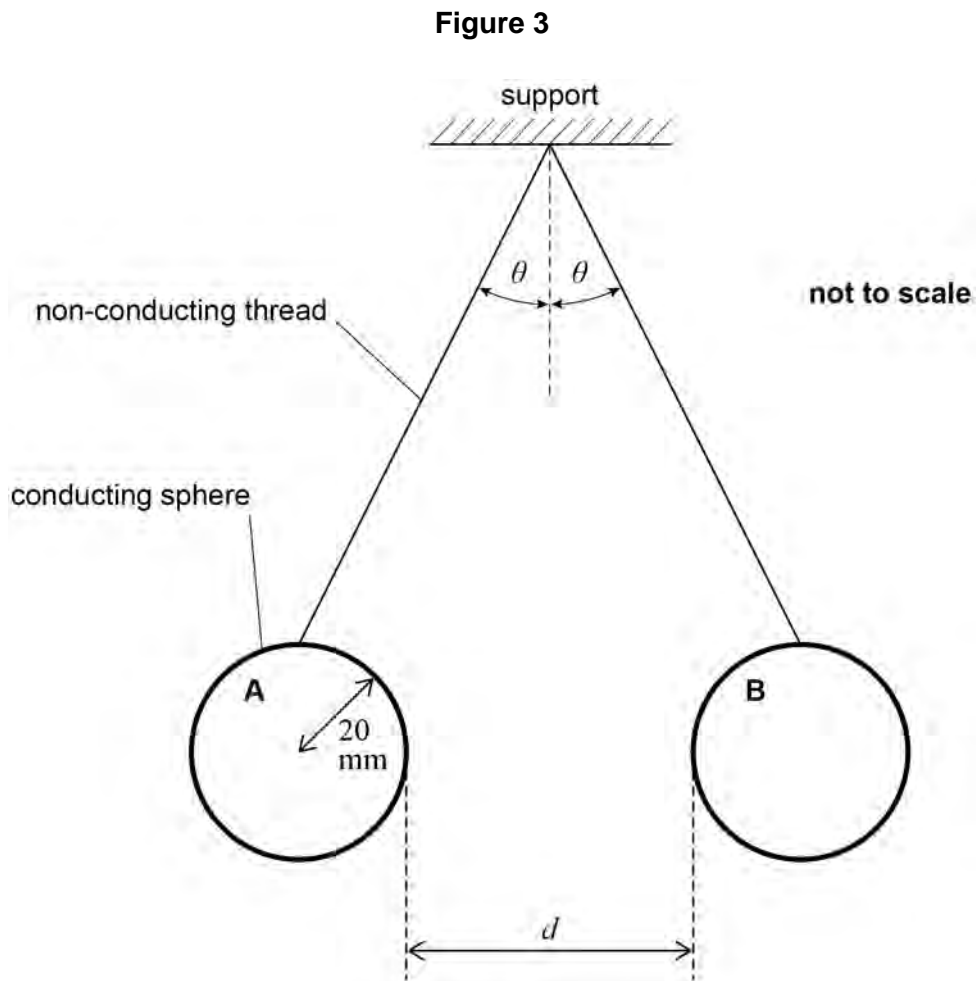

Each sphere has a mass of 3.2×10^{-3} kg and a radius of 20 mm.
The distance d is 40 mm.

The capacitance of a sphere of radius r is $4\pi\epsilon_0 r$.

Each sphere is charged by connecting it briefly to the positive terminal of a high-voltage supply, the other terminal of which is at 0 V.
After this has been done the charge on each sphere is 52 nC.



0 4 . 1 Calculate the potential of one of the spheres.

[3 marks]

potential = _____ V

0 4 . 2 The charged spheres in **Figure 3** are at equilibrium.

Draw labelled arrows on **Figure 3** to show the forces on sphere **B**.

[2 marks]

0 4 . 3 Suggest a solution to **one** problem involved in the measurement of d in **Figure 3**.

[2 marks]

Question 4 continues on the next page

Turn over ►



0 4 . 4

Show that the magnitude of the electrostatic force on each sphere is about 4×10^{-3} N.
[3 marks]

0 4 . 5

A student measures the angle θ when the apparatus in **Figure 3** is at equilibrium.
The student records θ as 7° .

Discuss whether this measurement is consistent with the other data in this investigation.

[2 marks]



0 4 . 6

The student says that the gravitational force between the two spheres has no **significant** effect on the angle at which the spheres are in equilibrium.

Deduce with a calculation whether this statement is valid.

[2 marks]

14

Turn over ►



0 5

A square coil of wire is rotating at a constant angular speed about a horizontal axis. **Figure 4** shows the coil at one instant when the normal to the plane of the coil is at 30° to a magnetic field.

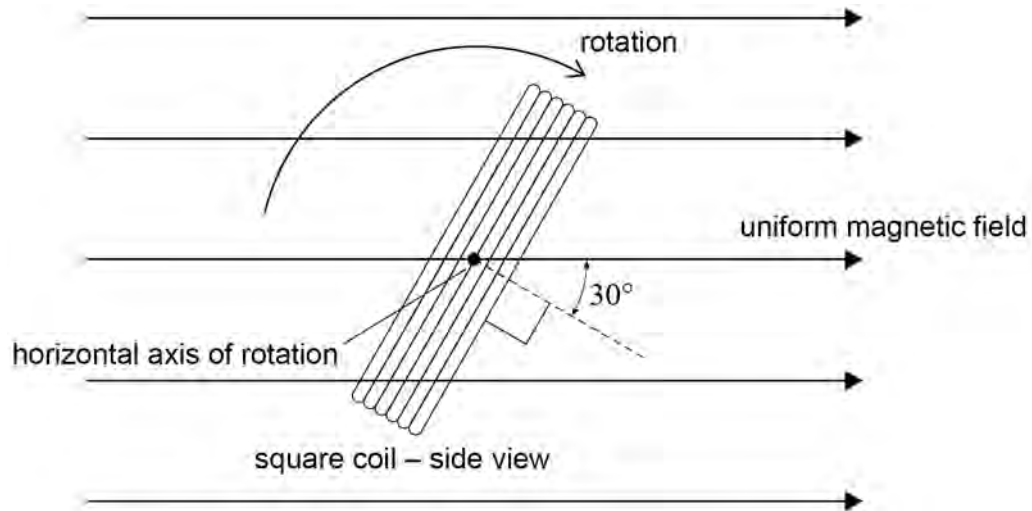
Figure 4

The area of the coil is $5.0 \times 10^{-4} \text{ m}^2$ and the flux density of the uniform magnetic field is $2.5 \times 10^{-2} \text{ T}$.



0 5 . 1

The maximum flux linkage of the coil during its rotation is 1.5×10^{-3} Wb turns.

Calculate the number of turns in the coil.

[2 marks]

number of turns = _____

0 5 . 2

Calculate the flux linkage of the coil at the instant shown in **Figure 4**.

[1 mark]

flux linkage = _____ Wb turns

Question 5 continues on the next page

Turn over ►



0 5 . 3

The coil forms part of an electrical generator. **Figure 5** shows the emf generated by the coil.

Figure 5

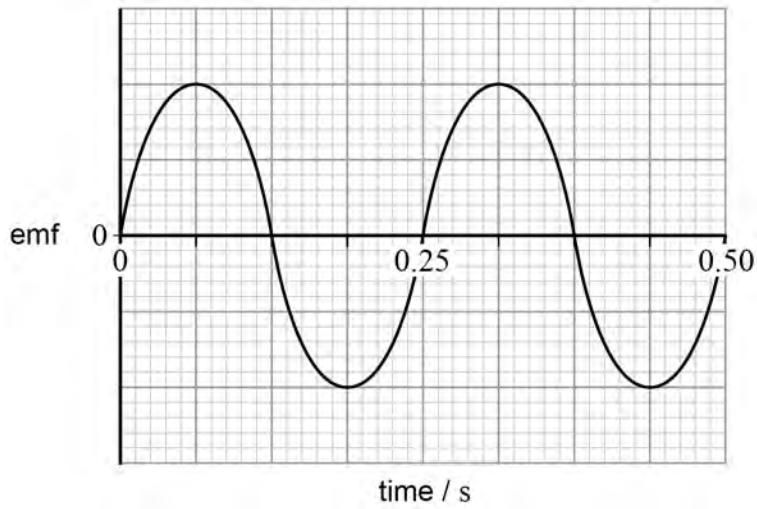

Calculate the peak value of the emf generated.

[2 marks]

emf = _____ V

0 5 . 4

Sketch on **Figure 6** the variation with time of flux linkage for the same time interval as **Figure 5**.

[1 mark]

Figure 6

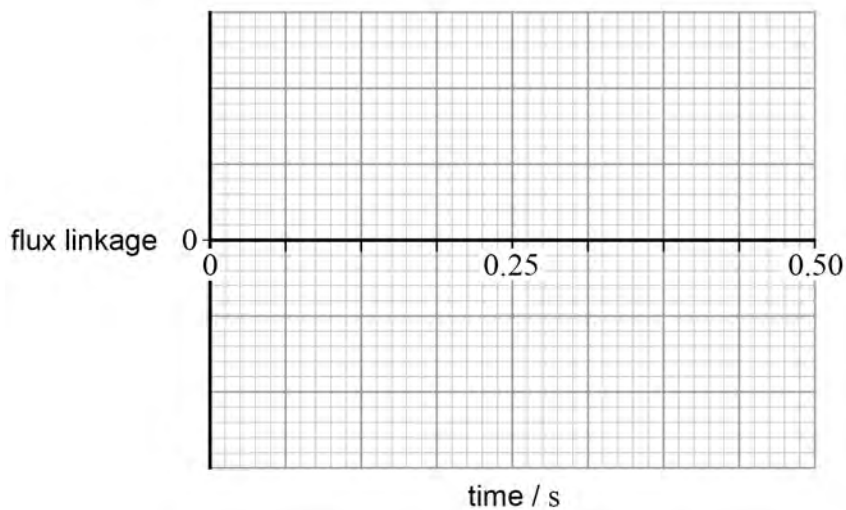

6



0 6

A thermal nuclear reactor uses a moderator to lower the kinetic energy of fast-moving neutrons.

0 6 . 1

Explain why the kinetic energy of neutrons must be reduced in a thermal nuclear reactor.

[1 mark]

0 6 . 2

As a result of a collision with an atom of a particular moderator, a neutron loses 63% of its kinetic energy.

A neutron has an initial kinetic energy of 2.0 MeV.

Calculate the kinetic energy of the neutron after five collisions.

[2 marks]

kinetic energy = _____ eV

Question 6 continues on the next page

Turn over ►

0	6	.	3
---	---	---	---

The kinetic energy of a neutron in a thermal nuclear reactor is reduced from about 2 MeV to about 1 eV.

Explain why the number of collisions needed to do this depends on the nucleon number of the moderator atoms.

[2 marks]



0 6 . 4

One fission process which can occur in a thermal nuclear reactor is represented by the equation

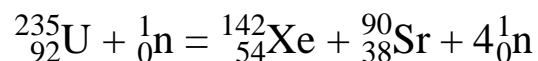

Calculate in MeV the energy released in this fission process.

$$\text{mass of } {}_{92}^{235}\text{U} = 235.044 \text{ u}$$

$$\text{mass of } {}_{54}^{142}\text{Xe} = 141.930 \text{ u}$$

$$\text{mass of } {}_{38}^{90}\text{Sr} = 89.908 \text{ u}$$

$$\text{mass of } {}_0^1\text{n} = 1.0087 \text{ u}$$

[3 marks]

energy released = _____ MeV

Question 6 continues on the next page

Turn over ►

0 6 . 5

Many magazine and newspaper articles focus on the risks of using nuclear power.

State **three benefits** of using nuclear power.

[3 marks]

1 _____

2 _____

3 _____

11

END OF SECTION A



Section B

Each of Questions **07** to **31** is followed by four responses, **A**, **B**, **C** and **D**.

For each question select the best response.

Only **one** answer per question is allowed.

For each question completely fill in the circle alongside the appropriate answer.

CORRECT METHOD 

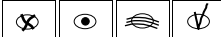
WRONG METHODS 





If you want to change your answer you must cross out your original answer as shown. 

If you wish to return to an answer previously crossed out, ring the answer you now wish to select as shown. 

You may do your working in the blank space around each question but this will not be marked.
Do **not** use additional sheets for this working.

07 Brownian motion

[1 mark]

- A** makes it possible to see the motion of air molecules. 
- B** is caused by the collisions of smoke particles. 
- C** is caused by collisions between air molecules and smoke particles. 
- D** occurs because air is a mixture of gases and the molecules have different masses. 

Turn over for the next question

Turn over ►



0 8 Which row shows two scalar quantities?

[1 mark]

A	gravitational potential	gravitational field strength	<input type="radio"/>
B	mass	gravitational potential	<input type="radio"/>
C	gravitational field strength	weight	<input type="radio"/>
D	weight	gravitational potential	<input type="radio"/>

0 9 What is the angular speed of a satellite in a geostationary orbit around the Earth?

[1 mark]

- A** $1.2 \times 10^{-5} \text{ rad s}^{-1}$
- B** $7.3 \times 10^{-5} \text{ rad s}^{-1}$
- C** $4.2 \times 10^{-3} \text{ rad s}^{-1}$
- D** $2.6 \times 10^{-1} \text{ rad s}^{-1}$

1 0 A planet of mass M and radius R rotates so quickly that material at its equator only just remains on its surface.

What is the period of rotation of the planet?

[1 mark]

- A** $2\pi\sqrt{\frac{R}{GM}}$
- B** $2\pi\sqrt{\frac{GM}{R}}$
- C** $2\pi\sqrt{\frac{R^3}{GM}}$
- D** $2\pi\sqrt{\frac{GM}{R^3}}$



1 1

Satellites **N** and **F** have the same mass and are in circular orbits about the same planet. The orbital radius of **F** is greater than that of **N**.

Which is greater for **F** than for **N**?

[1 mark]

A gravitational force on the satellite

B angular speed

C kinetic energy

D orbital period

1 2

An object moves freely at 90° to the direction of a gravitational field.

The acceleration of the object is

[1 mark]

A zero.

B opposite to the direction of the gravitational field.

C in the direction of the gravitational field.

D at 90° to the direction of the gravitational field.

Turn over for the next question

Turn over ►



1 3

When an electron is moving at a speed v perpendicular to a uniform magnetic field of flux density B , it follows a path of radius R .

A second electron moves at a speed $\frac{v}{2}$ perpendicular to a uniform magnetic field of flux density $4B$.

What is the radius of the path of the second electron?

[1 mark]

A $\frac{R}{8}$

B $\frac{R}{4}$

C $2R$

D $8R$

1 4

A small object of mass m has a charge Q . The object remains stationary in an evacuated space between two horizontal plates. The plates are separated by a distance d and the potential difference between the plates is V .

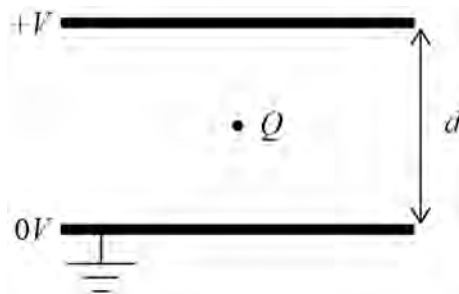

What is V ?

[1 mark]

A $\frac{mQg}{d}$

B $\frac{mdg}{Q}$

C $\frac{mQ}{d}$

D $\frac{md}{Q}$



1 5

1.5 mJ of work is done when a charge of $30 \mu\text{C}$ is moved between two points, **M** and **N**, in an electric field.

What is the potential difference between **M** and **N**?

[1 mark]**A** 20 mV**B** 20 V**C** 45 V**D** 50 V**1 6**

An electric field acts into the plane of the paper. An electron enters the field at 90° to the field lines.

The force on the electron is

[1 mark]**A** zero.**B** along the direction of the field.**C** at 90° to the field.**D** opposite to the direction of the field.**1 7**

The ionisation potential for the atoms of a gas is V . Electrons of mass m and charge e travelling at a speed v can just cause ionisation of atoms in the gas.

What is v ?

[1 mark]**A** $\frac{eV}{2m}$ **B** $\frac{2eV}{m}$ **C** $\sqrt{\frac{eV}{2m}}$ **D** $\sqrt{\frac{2eV}{m}}$ **Turn over ►**

1 8

When a small radioactive source is placed in a cloud chamber, straight tracks about 4 cm long are observed. The same source is placed 10 cm from a Geiger tube and a count rate is detected. When a sheet of aluminium 5 mm thick is placed between the source and the Geiger tube the count rate falls to the background count rate.

Which types of radiation are emitted by the source?

[1 mark]**A** α , β and γ **B** β and γ **C** α and γ **D** α and β **1 9**

A parallel-plate capacitor is made by inserting a sheet of dielectric material between two plates. Both plates are in contact with the sheet.

Which relative permittivity and sheet thickness give the greatest capacitance?

[1 mark]

	Relative permittivity	Thickness / mm	
A	2	0.40	<input type="checkbox"/>
B	3	0.90	<input type="checkbox"/>
C	4	1.0	<input type="checkbox"/>
D	6	1.6	<input type="checkbox"/>



2 0 A $1.0 \mu\text{F}$ capacitor is charged for 20 s using a constant current of $10 \mu\text{A}$.

What is the energy transferred to the capacitor?

[1 mark]

A $5.0 \times 10^{-3} \text{ J}$

B $1.0 \times 10^{-2} \text{ J}$

C $2.0 \times 10^{-2} \text{ J}$

D $4.0 \times 10^{-2} \text{ J}$

2 1 A $1.0 \mu\text{F}$ capacitor initially stores $15 \mu\text{C}$ of charge. It then discharges through a 25Ω resistor.

What is the maximum current during the discharge of the capacitor?

[1 mark]

A 0.60 mA

B 1.2 mA

C 0.60 A

D 1.2 A

2 2 The initial potential difference across a capacitor is V_0 . The capacitor discharges through a circuit of time constant T . The base of natural logarithms is e .

What is the potential difference across the capacitor after time T ?

[1 mark]

A $\frac{V_0}{2}$

B $\frac{V_0}{e}$

C $V_0 e$

D $V_0 \ln 2$

Turn over ►



2 3

The plane of coil **PQRS** is parallel to a uniform magnetic field.

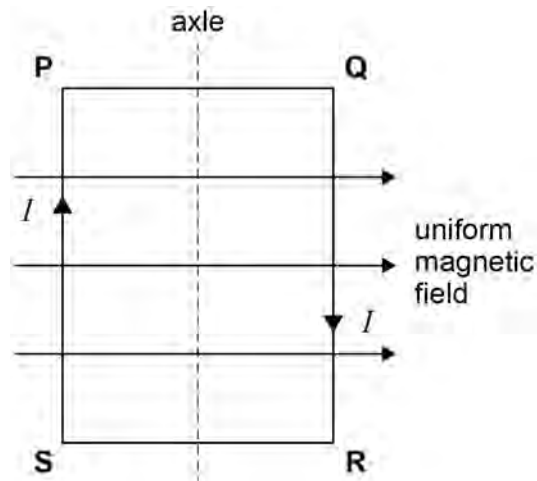

When a current I is in the coil

[1 mark]

- A** there are no magnetic forces acting on **SP** and **QR**.
- B** there are no magnetic forces acting on **PQ** and **RS**.
- C** an attractive magnetic force acts between **SP** and **QR**.
- D** an attractive magnetic force acts between **PQ** and **RS**.

2 4

A horizontal wire of length 0.50 m and weight 1.0 N is placed in a uniform horizontal magnetic field of flux density 1.5 T directed at 90° to the wire.

What is the current that just supports the wire?

[1 mark]

- A** 0.33 A
- B** 0.75 A
- C** 1.3 A
- D** 3.0 A



2 5

Which is **not** an assumption about gas particles in the kinetic theory model for a gas?

[1 mark]

- A** They collide elastically with the container walls.
- B** They have negligible size compared to the distance between the container walls.
- C** They travel between the container walls in negligibly short times.
- D** They collide with the container walls in negligibly short times.

2 6

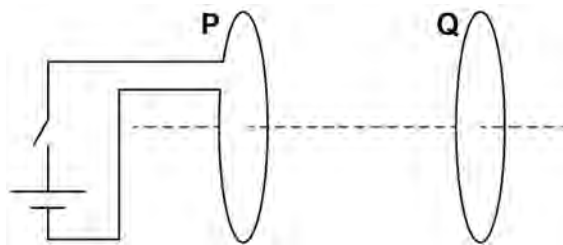
A coil **P** is connected to a cell and a switch.A second closed coil **Q** is parallel to **P** and is arranged on the same axis.When the switch is closed, coil **Q** experiences a force.Which row describes the force on **Q**?

[1 mark]

	Force	Direction of force	
A	increases to constant value	to left	<input type="radio"/>
B	increases to constant value	to right	<input type="radio"/>
C	increases then decreases	to left	<input type="radio"/>
D	increases then decreases	to right	<input type="radio"/>

Turn over ►



2 7

Three identical magnets **P**, **Q** and **R** are released simultaneously from rest and fall to the ground from the same height.

P falls directly to the ground.

Q falls through the centre of a thick horizontal conducting ring.

R falls through a similar ring that has a gap cut into it.

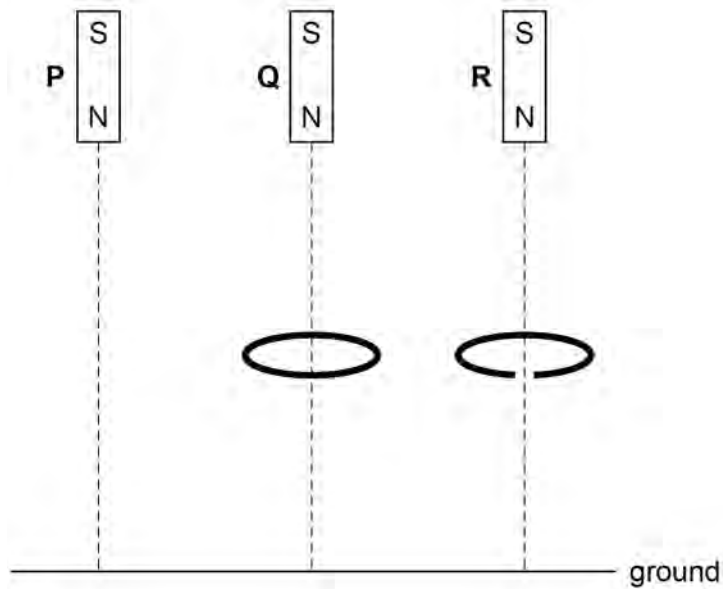

In which order do the magnets reach the ground?

[1 mark]

- A** **P** and **R** arrive together, followed by **Q**.
- B** **P** and **Q** arrive together, followed by **R**.
- C** **P** arrives first, followed by **Q** which is followed by **R**.
- D** All three magnets arrive simultaneously.



2 8

A steady current I dissipates power P in a resistor of resistance R .
An alternating current through a resistor of resistance $2R$ has a peak value of I .

What is the power dissipated in the second resistor?

[1 mark]

A $\frac{P}{\sqrt{2}}$

B P

C $\sqrt{2}P$

D $2P$

2 9

The figure shows an oscilloscope trace of a sinusoidal ac voltage.

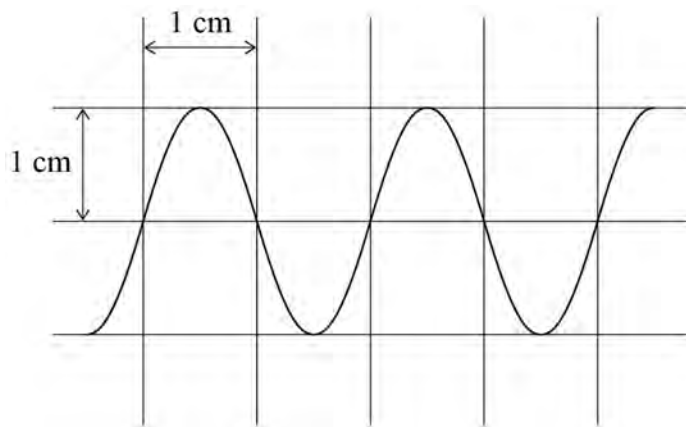

The time base setting is 5 ms cm^{-1} and the Y-voltage gain is 10 V cm^{-1} .

Which row describes the ac voltage?

[1 mark]

	rms voltage / V	Frequency / Hz	
A	14	50	<input type="checkbox"/>
B	14	100	<input type="checkbox"/>
C	7	50	<input type="checkbox"/>
D	7	100	<input type="checkbox"/>

Turn over ►

3 0

A deuterium nucleus and a tritium nucleus fuse together to form a helium nucleus and a particle X. The equation for this process is:

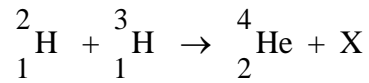

What is X?

[1 mark]

A electron

B neutron

C positron

D proton

3 1

What effect are the control rods intended to have on the average kinetic energy and number of fission neutrons in a thermal nuclear reactor?

[1 mark]

	Average kinetic energy of fission neutrons	Number of fission neutrons	
A	unchanged	unchanged	<input type="checkbox"/>
B	reduced	unchanged	<input type="checkbox"/>
C	unchanged	reduced	<input type="checkbox"/>
D	increased	reduced	<input type="checkbox"/>

25

END OF QUESTIONS



There are no questions printed on this page

*Do not write
outside the
box*

**DO NOT WRITE ON THIS PAGE
ANSWER IN THE SPACES PROVIDED**



